

Playful Puppy Robot

The playful puppy robot is a simple quadruped robot that uses an infrared compound eye to track movement at close range. These instructions will show you how to assemble and program your robot.

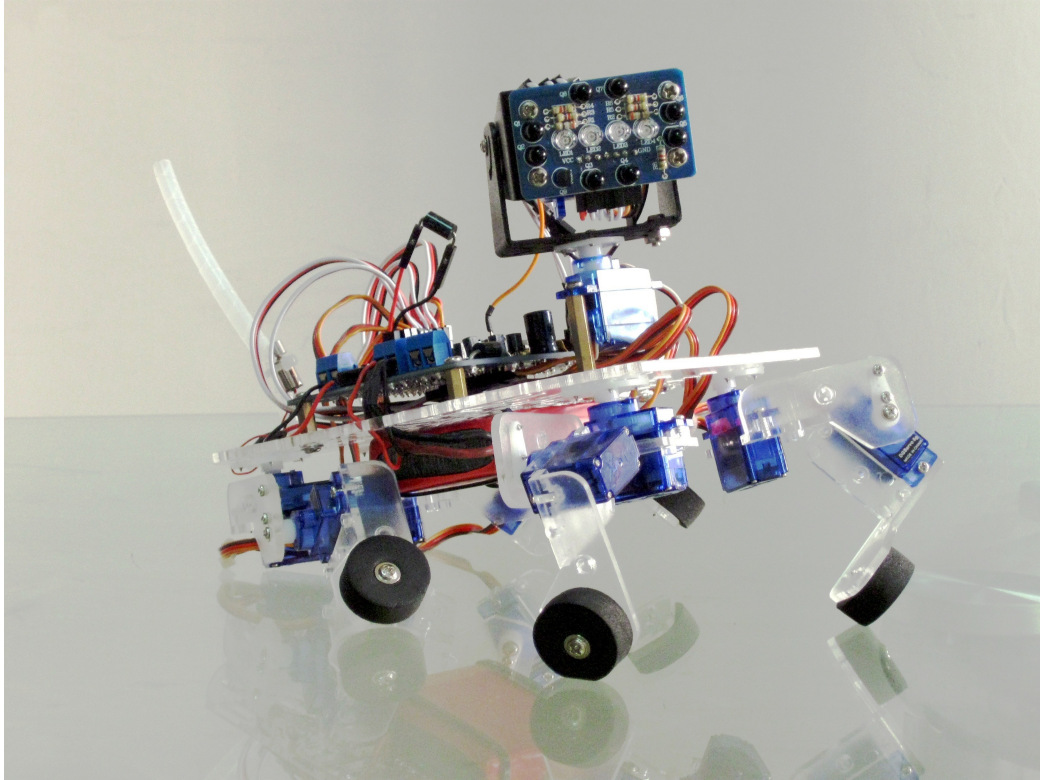

Required tools:

- #1 Phillips screwdriver.
- Small (2.4mm or 3/32 inch) flat head screwdriver.
- Long nose pliers.

The kit is supplied with a 3x2 AA battery holder. Good quality NiMh or NiCd batteries **must** be used. **Do not** attempt to use alkaline batteries as the voltage will be too high and could damage the servos. The robot will work better with a 7.4V LiPo battery as this is lighter.

There are two variations of the sample code depending on which battery you use. The difference is that the NiMh batteries are heavier and the robot needs slightly different code to balance on its hind legs.

The latest sample code can be downloaded at:

<https://sites.google.com/site/daguproducts/>

Types of screws used in this kit

Self-tapping screws have a coarse thread and pointed tip that can drill into soft materials like plastic and wood.

Machine screws have a fine thread and are designed to screw into machined parts where a thread is already present.

Pan head screws have an extra large head. This is the equivalent of using a separate washer and screw.

Step 1: Center your servos

The Quad Bot chassis kit includes 8x miniature servos and the Pan/Tilt kit includes 2 miniature servos. These servos have clear cases so you should be able to see through them well enough to check that they are centered.

When the servo is centered it can physically turn the same amount in each direction (approximately 90 degrees). Check that all 10 of your servos are centered. Once the robot is assembled, the center position of each servo can be refined in the software if required.

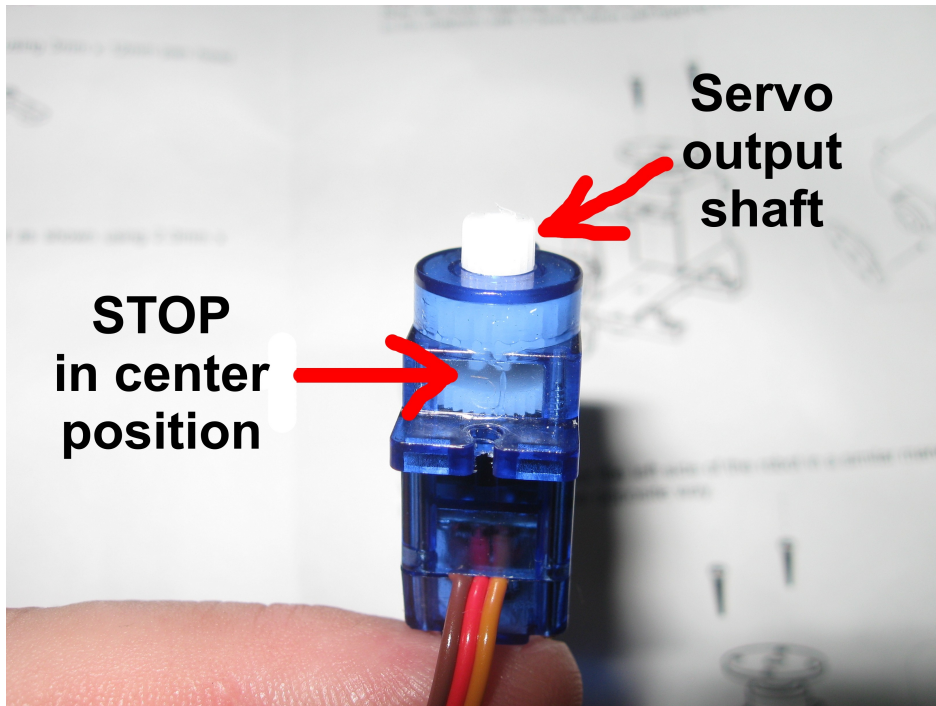

Step 2: Attach the foam rubber feet

There are 8 identical leg segments included in the kit. Select 4 of them and attach foam rubber feet using the 3 x 12mm pan head screws. There are only 4 of these screws and they are the largest so they are easy to find.



Step 3: Mount knee servos to legs

Mount 4 of your servos on the leg segments with the foam rubber feet. Use 2.3 x 8mm self-tapping screws. Make sure the output shaft is away from the foot as shown in the photo.

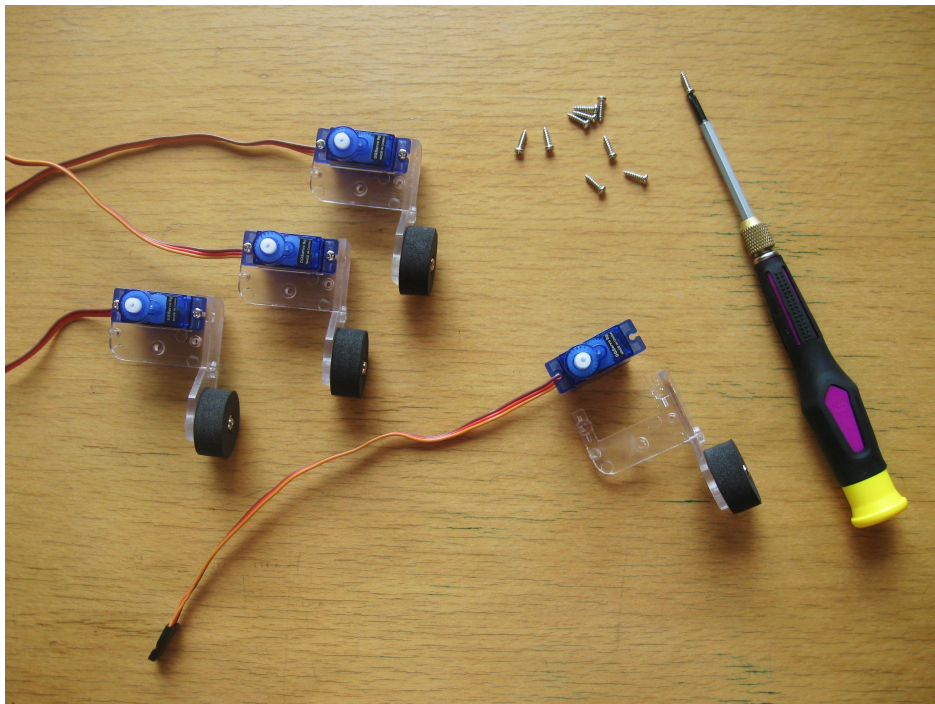

Step 4: Mount servo horns on the thigh segments

A servo horn is a piece of plastic that fits onto the output shaft of the servo and allows you to attach control rods or other devices using self-tapping screws. Take the 4 unused leg segments and fit servo horns as shown in the photo below using 2 x 6mm self-tapping screws. There are only 8 of these. Use two for each servo horn.

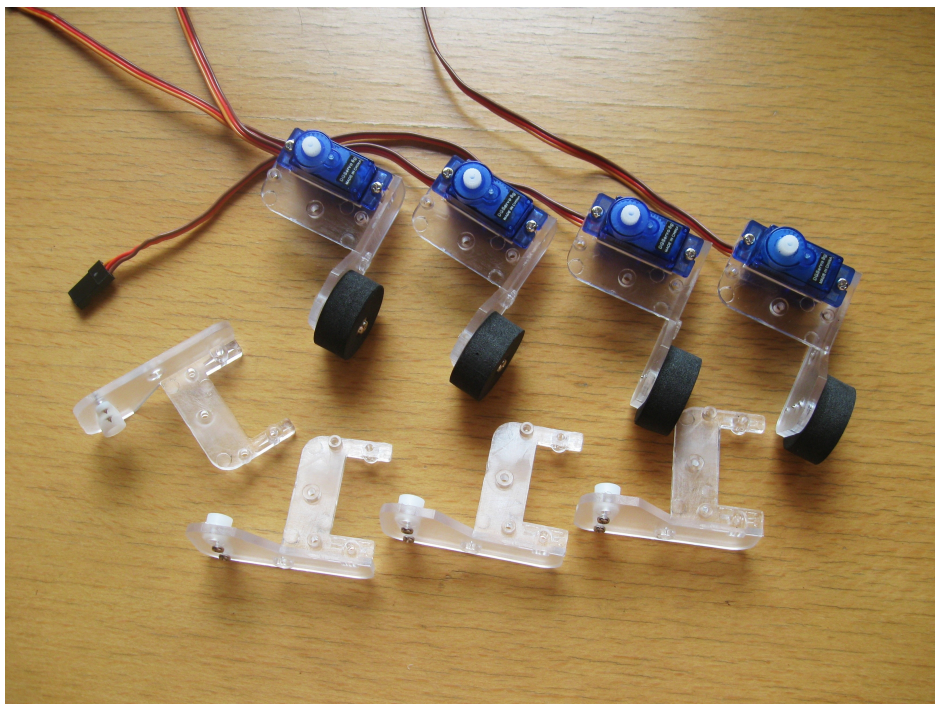

Step 5: Attach your thigh segment to your legs

Once you have mounted the servo horns on the thigh segments they can be attached to your knee servos using 4 of the 8 supplied 2 x 8mm pan head screws. With your knee servo centered the thighs should be at 90 degrees to the leg segment with the foam rubber foot.

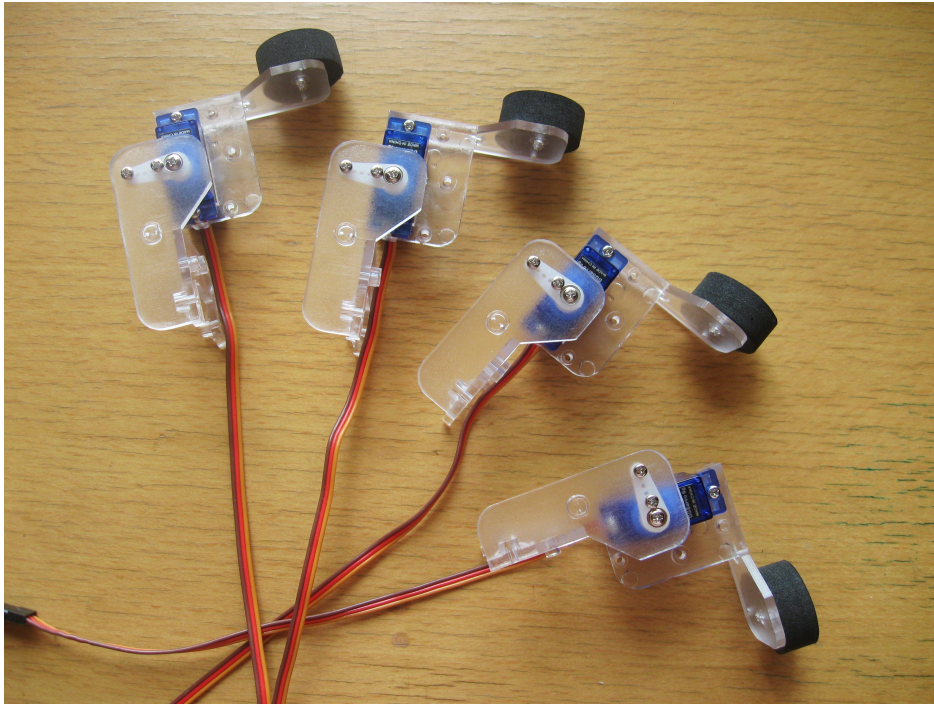

Step 6: Left and Right legs

So far all of your legs should look identical. Now we will separate them into left and right legs. The only difference between a left leg and a right leg is the way in which the thigh servo is mounted. Mount your thigh servos as shown in the photo using the 2 x 8mm self-tapping screws. Note the difference in the position of the output shaft in the left leg thigh servos compared to the right leg thigh servos. They are mirror imaged.

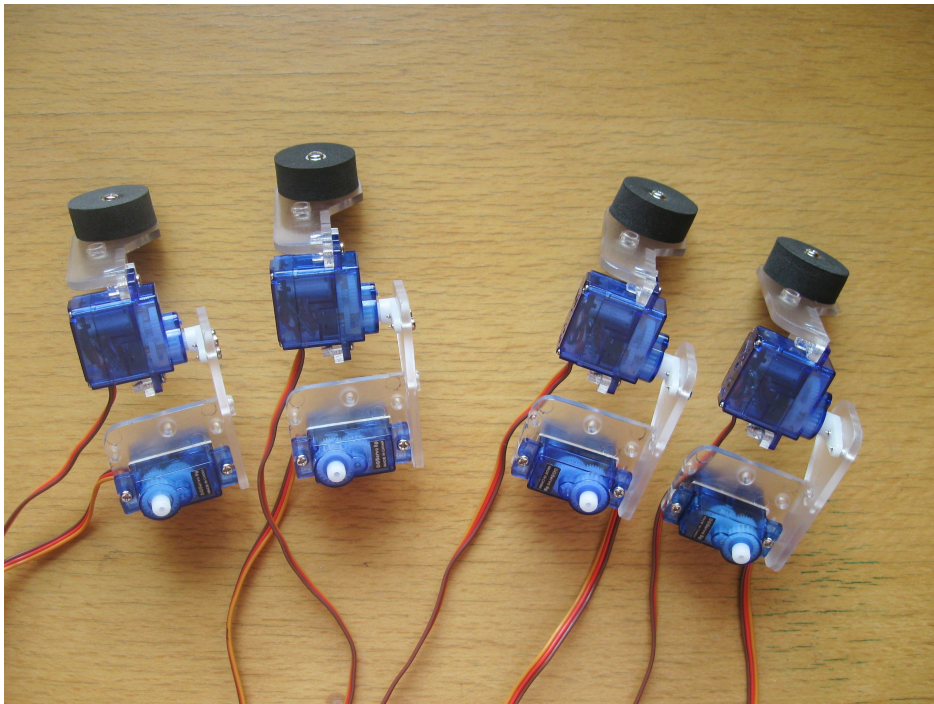

Step 7: Attach your legs to the mounting plate

The mounting plate of the Quad Bot chassis is the laser cut acrylic panel that you mount all your parts on. Mount your left and right legs as shown in the photo. **NOTE:** the rounded end is the rear of your robot. The hole in the center of the rear is where you will mount your tail.

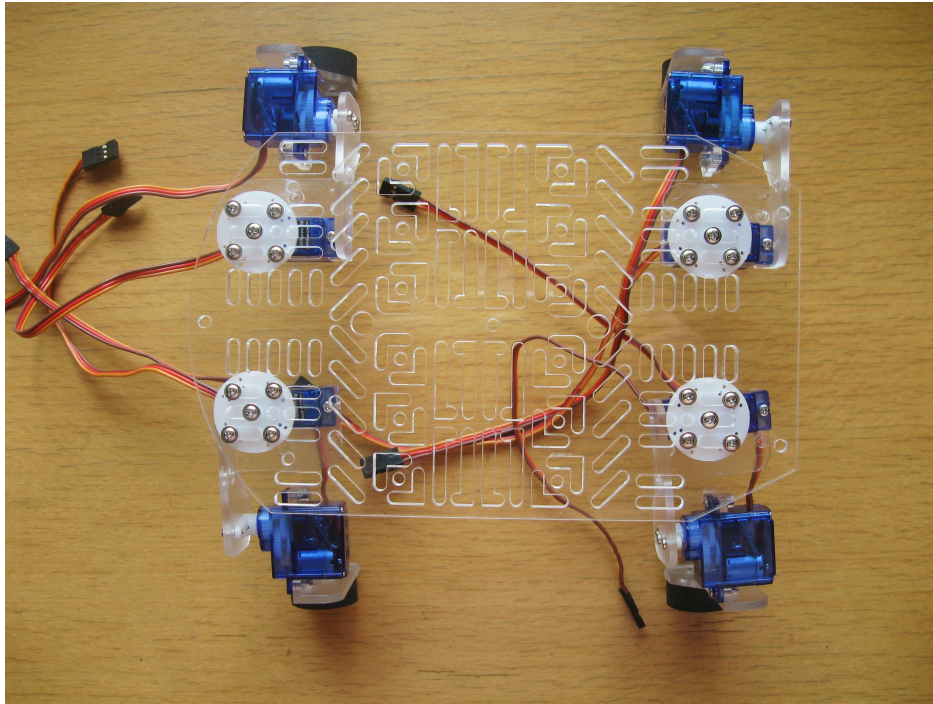

Step 8: Fit mounting spacers to pan servo.

The brass hex spacers used to mount the pan / tilt kit require a 3mm screw but the miniature servo housing has a hole designed for a 2mm screw. Use the Phillips head screwdriver to ream out the holes on each side. Do not press to hard, you only need to ream out each side of the hole by a small amount so that the 3mm screw can be inserted without too much force.

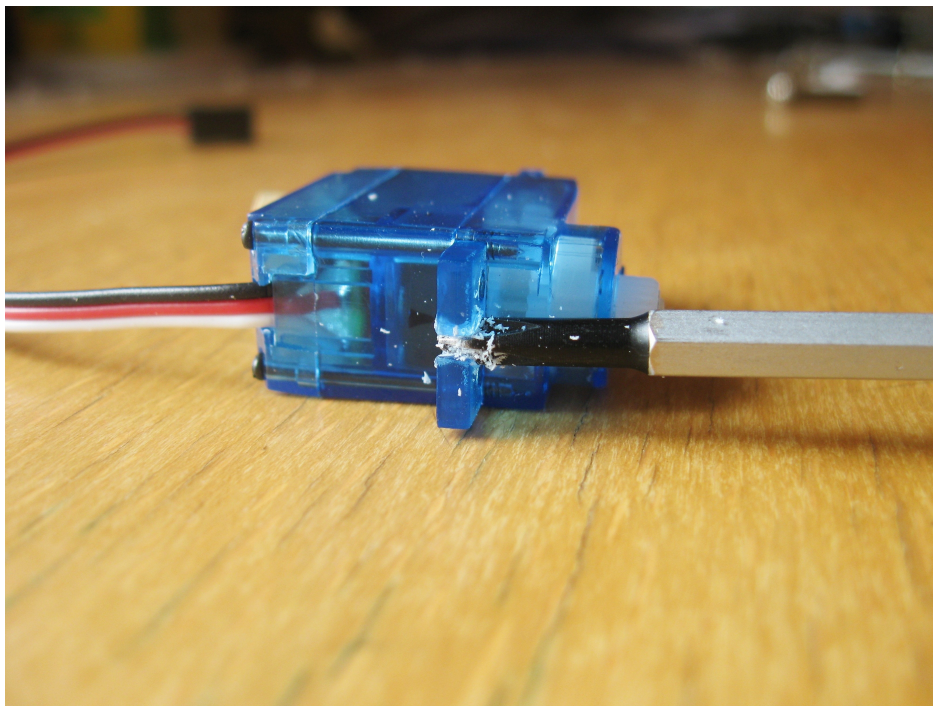

Once you have the 3mm screw in all the way, continue turning the screw a few times so that the screw thread can drill out the hole a bit more.

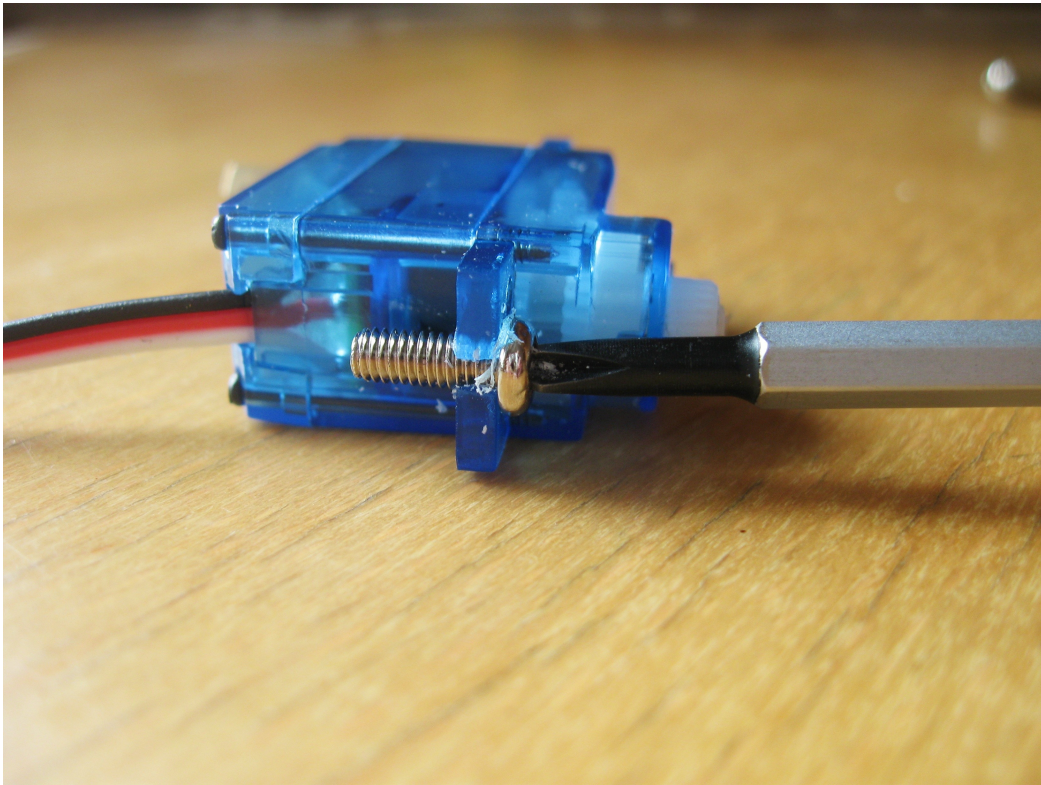

You can now easily fit your 25mm (1 inch) brass hex spacers. Use your pliers if necessary to hold the brass spacers when tightening the screws. **Do not over tighten** otherwise you will crack the servo mounts.

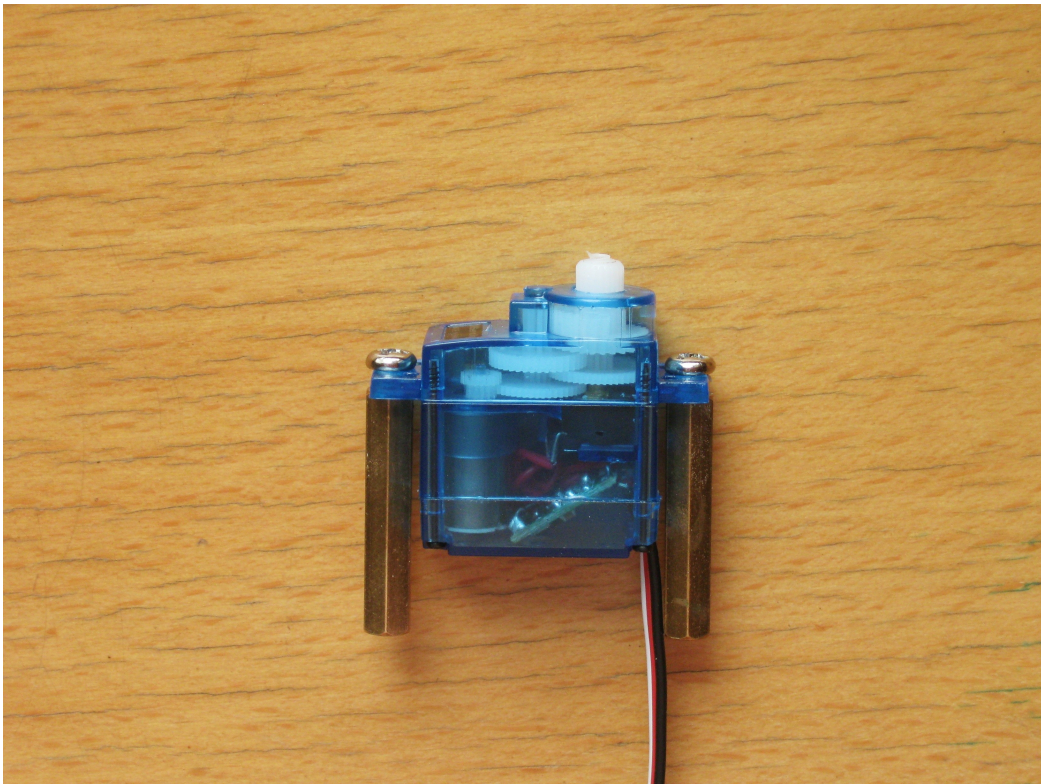

Step 9: Attach the pan servo to the pan bracket

The pan / tilt kit comes with two large brackets. Each bracket has a different hole pattern on it to suit many different sensors. Look at the photo below and make sure you attach the correct bracket to the pan servo, as the compound eye cannot be mounted if you use the wrong bracket. Use 2 x 6mm pan head screws to mount the bracket to the round servo horn and another 2 x 6mm pan head screw to mount the servo horn onto the pan servo as shown.

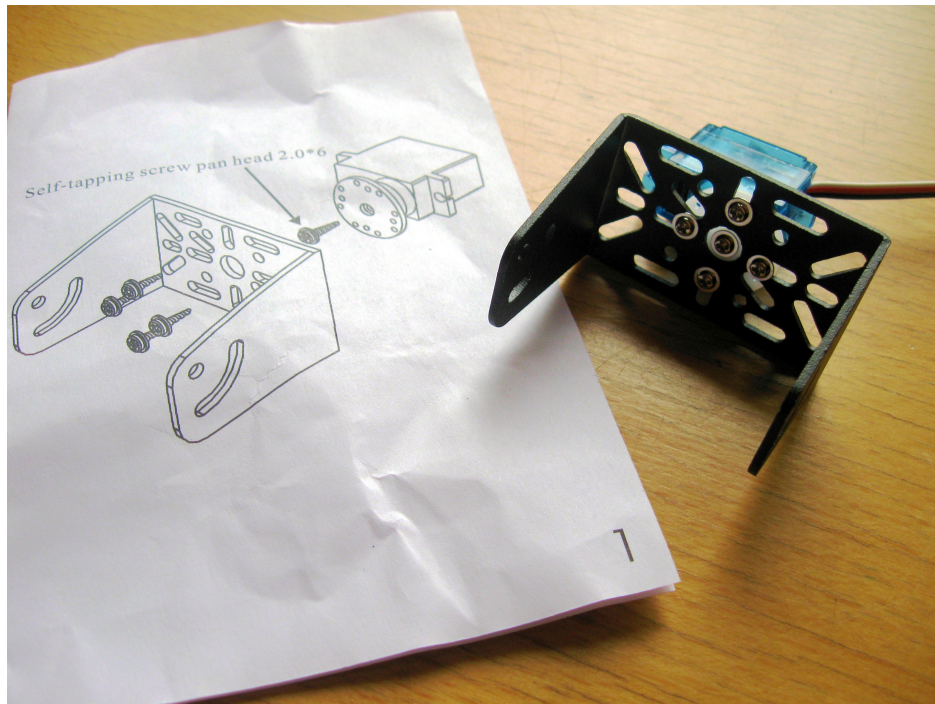

Step 10: Attach the tilt servo-locating bracket

The tilt servo-locating bracket doesn't actually hold the tilt servo in place. Its main purpose is to prevent the tilt servo from twisting while allowing some play so the servo can self center. This bracket is mounted using two 3 x 6mm machine thread screws and two 3mm nuts. **Leave these nuts slightly loose** at this stage so that the bracket can move forwards and backwards slightly. We will tighten them once the servo is aligned.

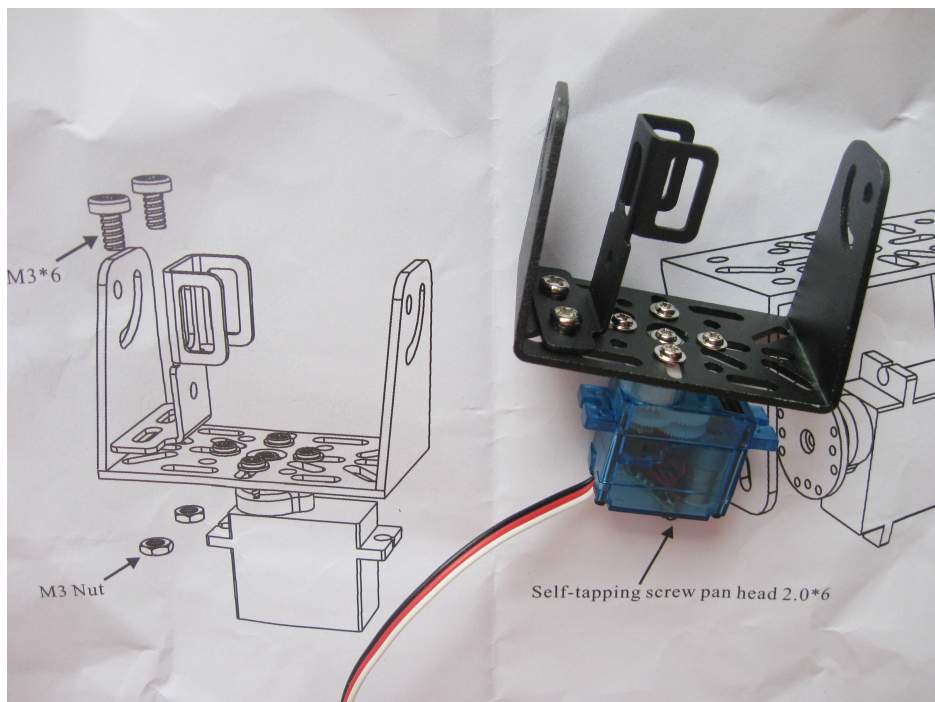

Step 11: Attach the servo horn to the tilt bracket

Use two 2 x 6mm pan-head screws to attach a round servo horn to the tilt bracket. Use holes that will allow the center hole of the servo horn to align with the bracket as shown without allowing too much play if the screws come loose.



Step 12: Align the tilt servo

Use a 2.3 x 12mm screw to align your tilt servo. The servo will be a firm fit in the tilt servo locating bracket. Adjust the position so that the servo aligns with the pan bracket and allow room for spacer washers and a servo horn. Once everything is aligned you can tighten the 3mm screws holding the tilt servo-locating bracket so that it won't move.

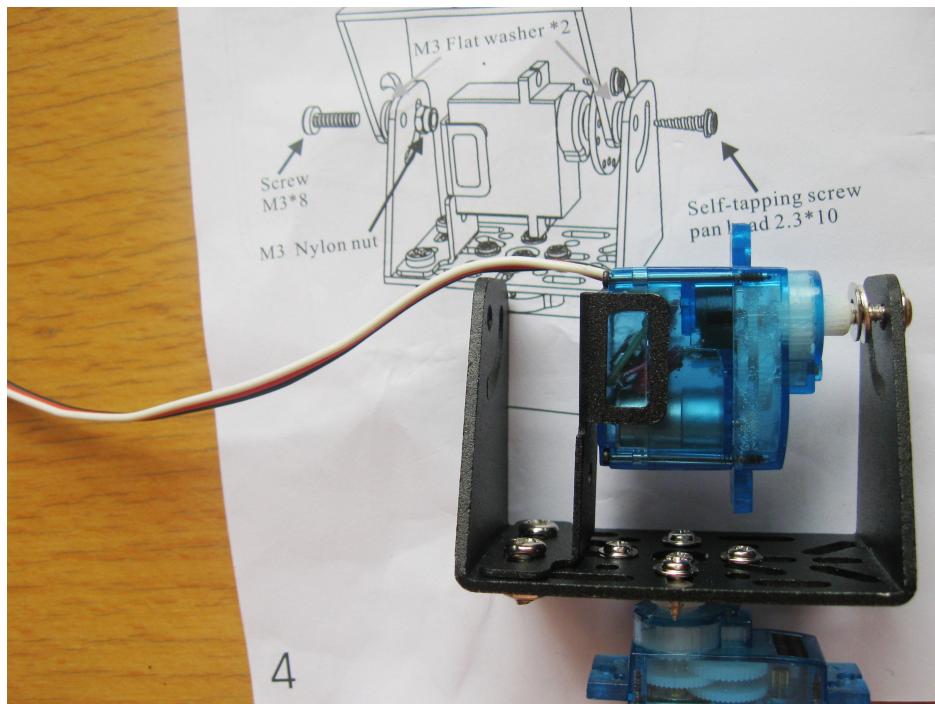

Step 13: Mount the tilt bracket

There are some spacer washers that must be inserted so that the tilt assembly can rotate smoothly. The easiest way I know to insert these spacer washers is to lie the pan / tilt assembly on it's side with the tilt bracket at about 40 degrees when the tilt servo is centered as shown in the first photo.

Stack your spacer washers neatly and insert them as best you can with your hand or long nose pliers as shown in the second photo. Use a plastic cable tie to gently push the washers into position as shown in the third photo. Once the holes line up it's easy to insert your 2.3 x 10mm screw through the brackets and washers into the servo output shaft.

Tighten all the way being careful not to over tighten and then back off 1/4 of a turn. The tilt bracket should be able to tilt up and down fairly easily. Loosen the screw a little more if required. Do the same on the other side with the 3 x 10mm machine screw and nylon nut. **NOTE:** The nylon nut should be slightly loose so that the tilt assembly can move easily.

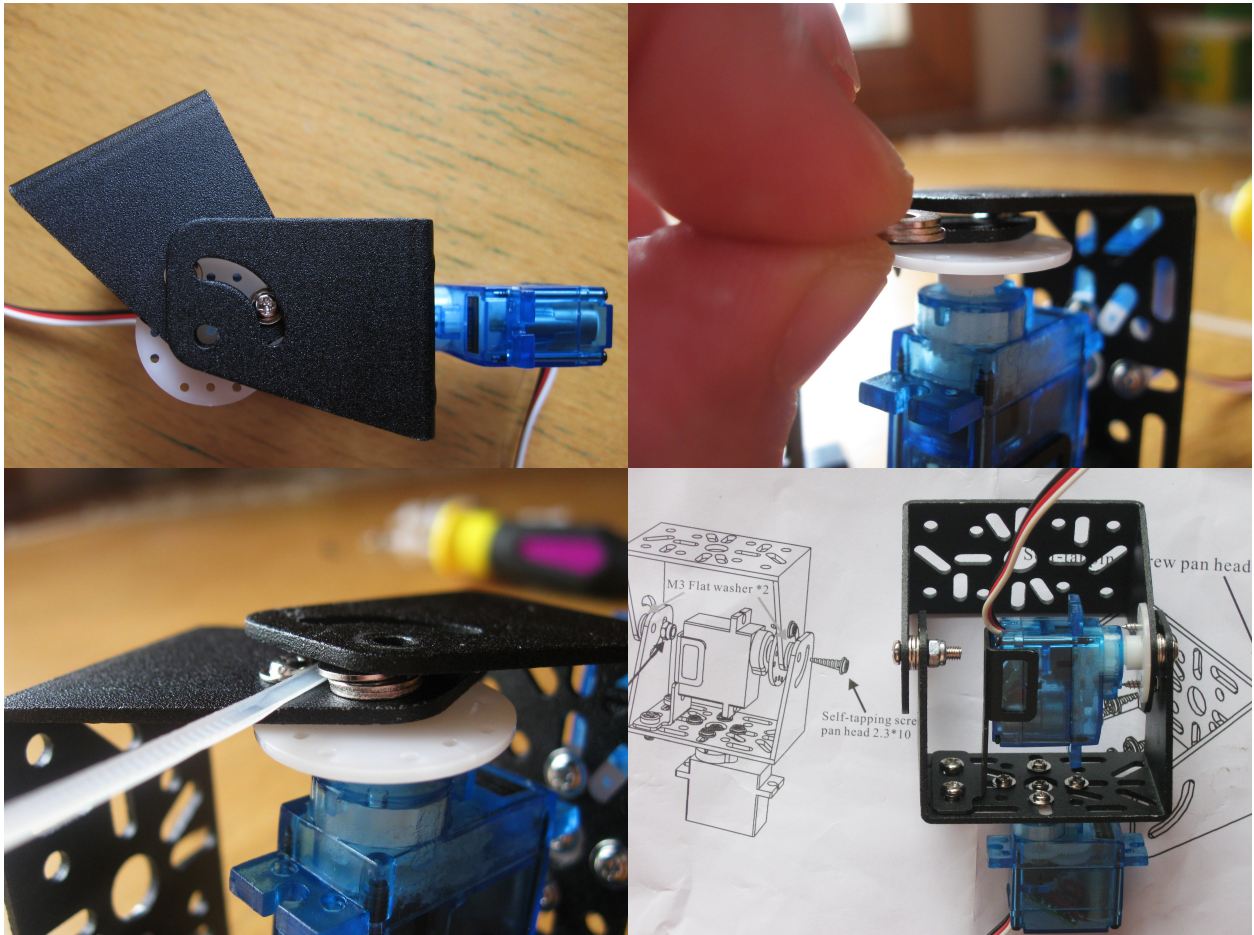

Step 14: Mount the eye

The IR compound eye is a simple sensor that measures ambient light and reflected IR light from an object. The eye has seven connectors as shown in the first photo. Vcc (+5V) and Ground for power. The IR LEDs pin turns the IR LEDs on or off and then there are 4 analog outputs for up, down, left and right.

Attach the four mounting spacers on the tilt bracket as shown in the second photo. Make sure the 3mm nuts are tight. Connect 8cm female-to-female jumper wires to the eye as shown in the third photo. I've used red for Vcc (+5V), black for ground (0V), orange for the IR LEDs and white for the 4 analog outputs.

Because 8cm is not long enough I have then attached 8cm male-to-male jumper wires. This gives me 160mm female to male jumper wires as shown in the third photo. By running the wires under the tilt bracket and then over the tilt servo as shown in the fourth photo I find the head can move freely in any direction without pulling on the wires too much.

Eye connections

1. +5V
2. Top
3. Left
4. Bottom
5. Right
6. IR LEDs
7. 0V

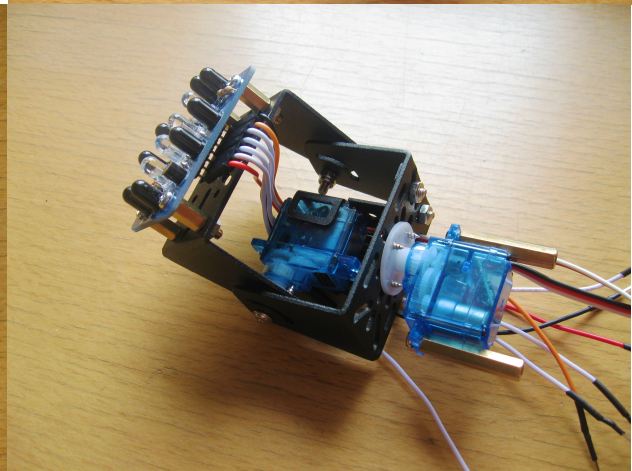
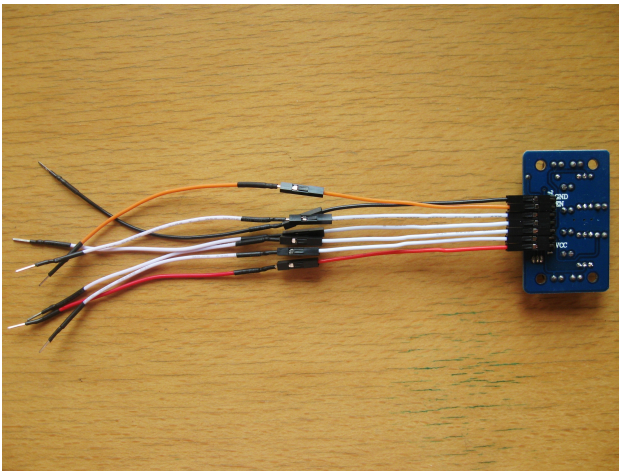
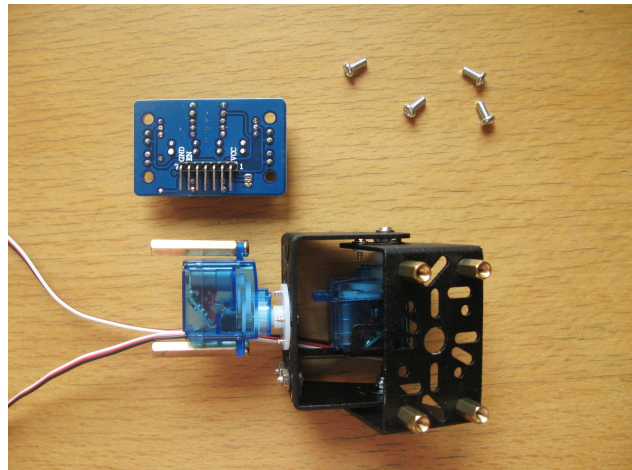
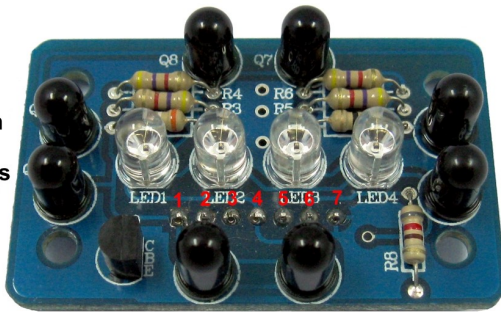

Step 15: Mount the head onto the body

Use two 3 x 10mm pan head machine screws to mount the head. Notice the holes used in the first photo. The servo is mounted slightly to one side so that the pan servo's output shaft is centered rather than the servo body. The pan servo is mounted a reasonable distance back to improve the balance of the robot and to help protect the pan servo if the robot runs into a wall.

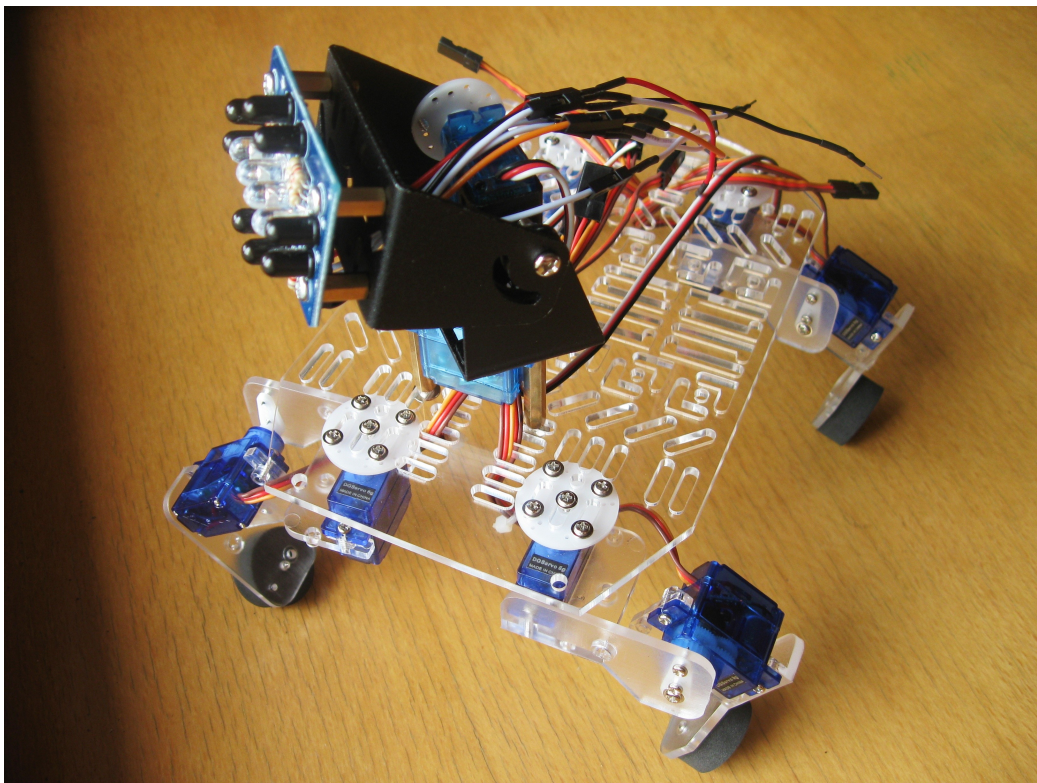
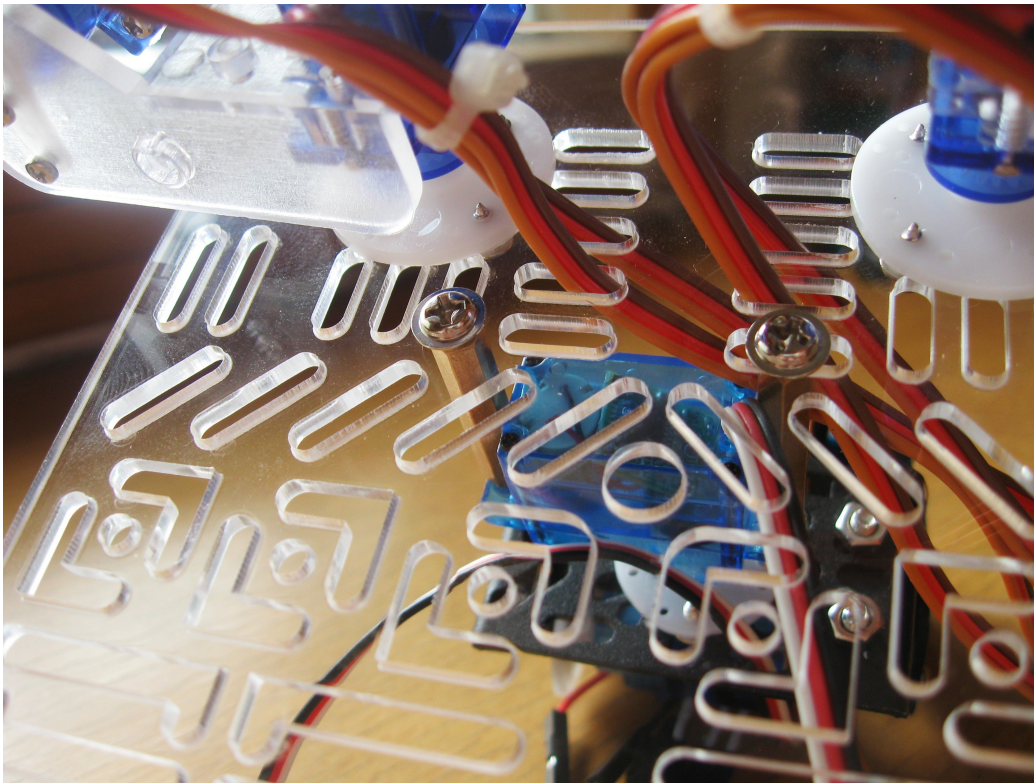

Step 16: Mount your batteries

This robot works best with a small LiPo battery (7.4V, 2300mAh) but rechargeable AA NiMh batteries are more common and easier to recharge so we will use 6x AA NiMh batteries for these instructions. Do not use alkaline batteries, the voltage is too high and they cannot put out enough current to drive the servos. This will cause your processor to continually reset. Use good quality batteries with at least 2000mAh capacity.

Place some tape on the ends of the wires before you start so that they can't short out before you are ready to connect them and then install 6 fully charged batteries.

Cable tie your battery holder to the centre of the mounting plate with your wires on the right hand side. Make sure all legs can move inward about 45 degrees without hitting it. **Do not make the cable ties too tight!** You should be able to just slide the battery holder sideways out of the cable ties when it is time to recharge the batteries.

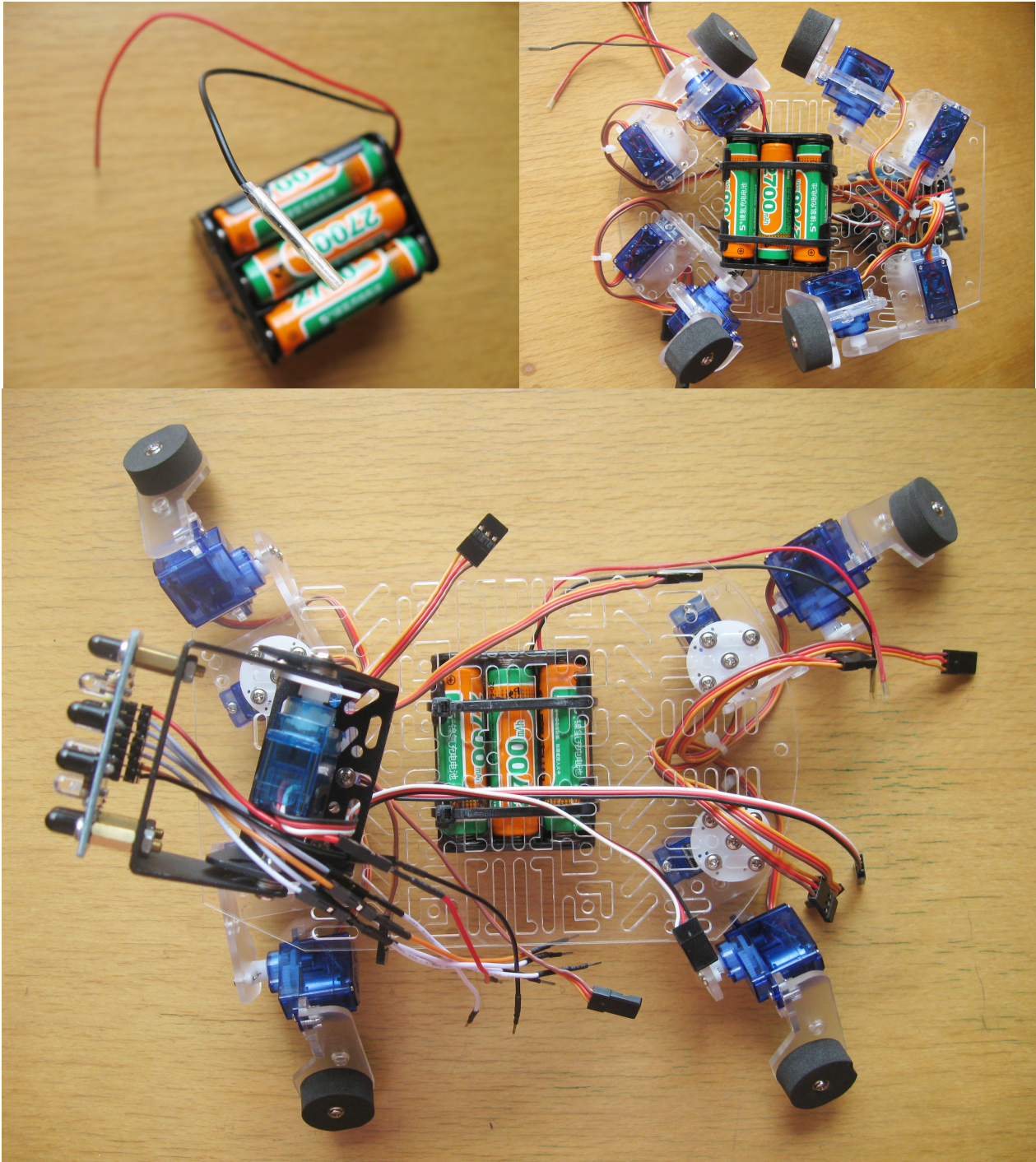

Step 17: Mount the Magician robot controller

Attach the four supplied brass spacers to the corners of the controller PCB. Now mount the board on the chassis with the power connection on the right hand side and the analog pins closest to the head as shown in the second photo.

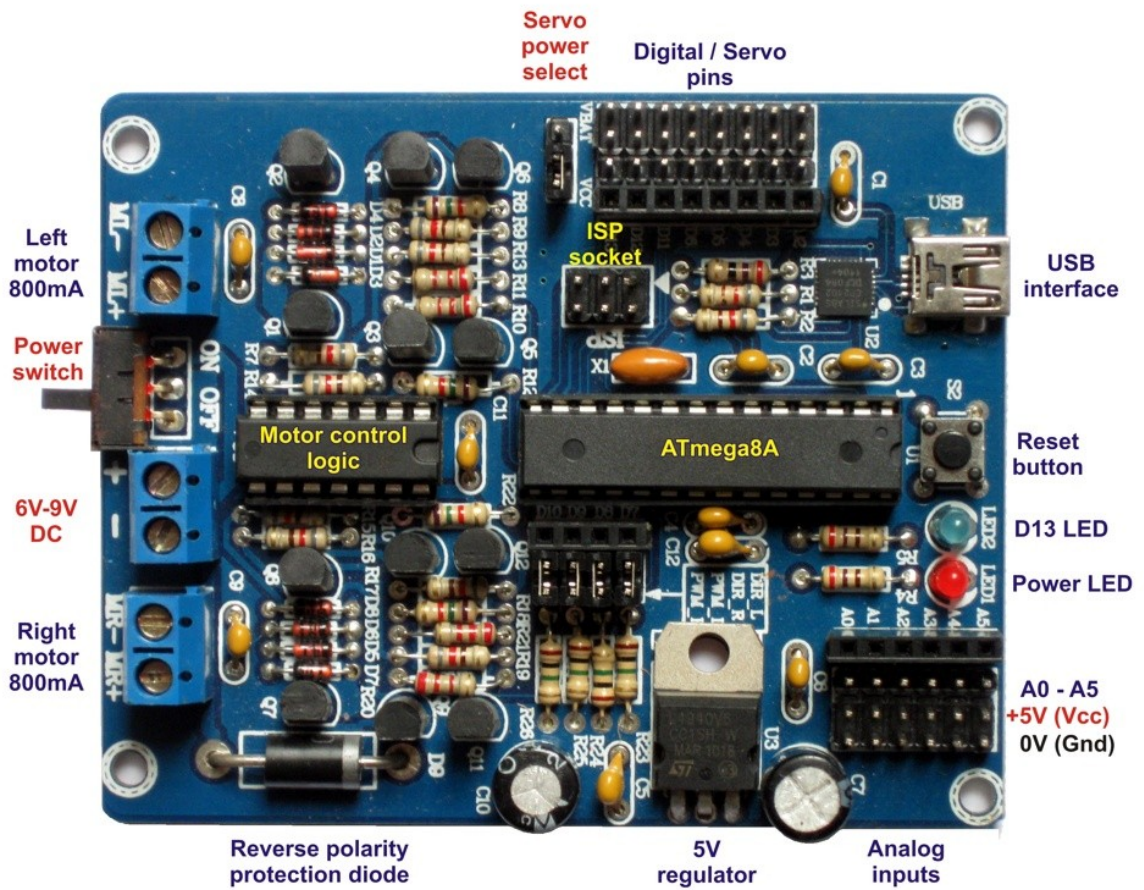
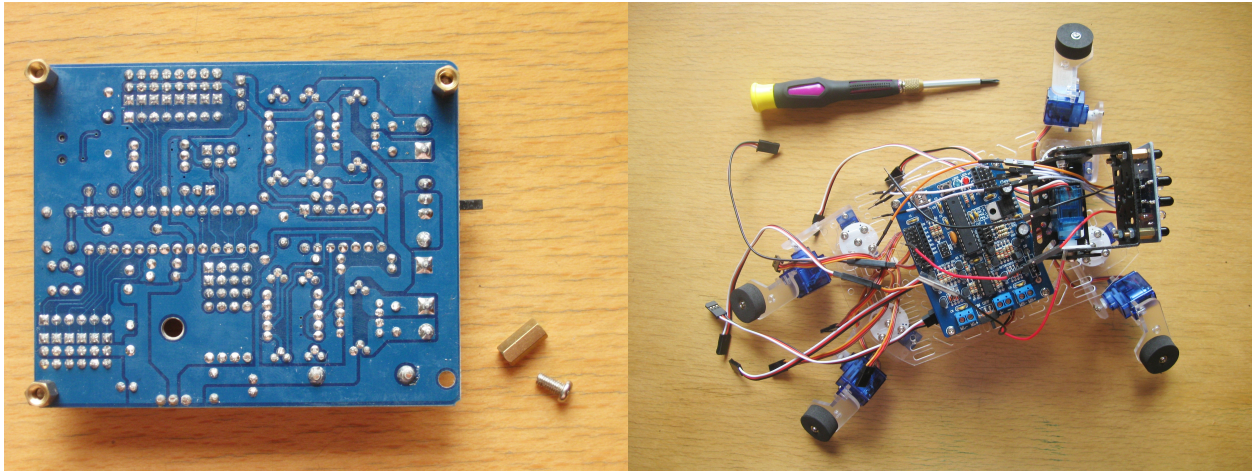

Step 18: Wire up the head

Connect your pan servo to A4 and your tilt servo to A5 with the white signal wire towards the female header. The software reconfigures these pins as servo outputs. Fit small red and black female-to-female jumper wires to Vcc and ground as shown in the photo. These will provide power for the infrared compound eye. Connect the red and black power wires from the eye.

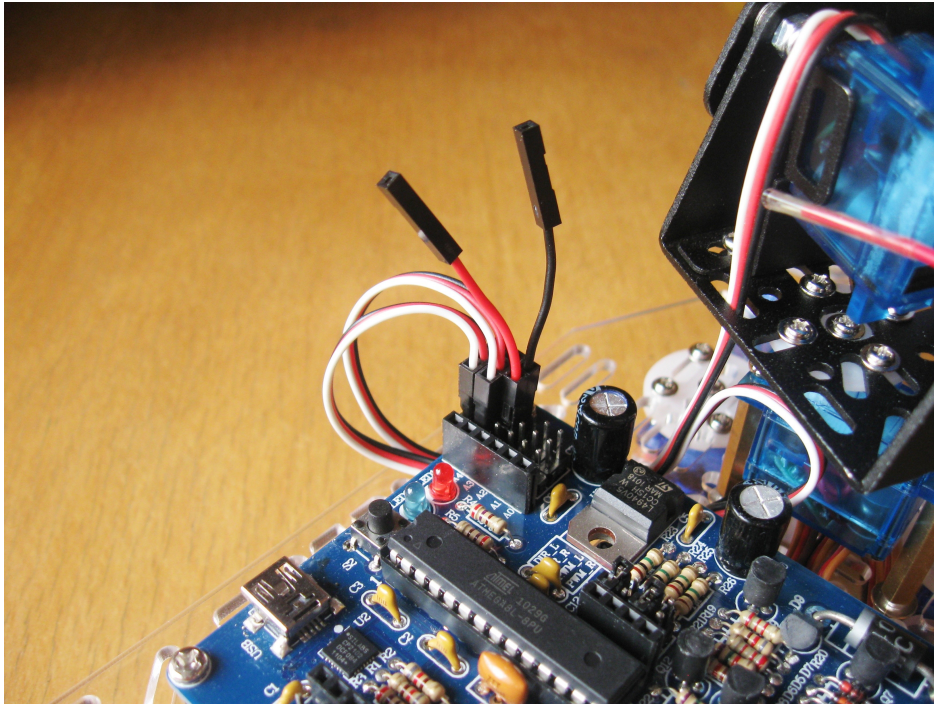

The motor control circuitry connects to the processor via 4 jumpers. Remove the jumpers on D8 and D10. Leave the jumpers on D7 and D9. This allows us to use D8 to control the IR LEDs on the eye. D10 might be used to control a small speaker or LED. The left motor control circuit is still connected and is used to drive a small shaker motor to make the tail wag.

Connect your orange jumper wire to D8 and connect your 4 analog outputs from your eye. A0 is up, A1 is left, A2 is down, A3 is right.

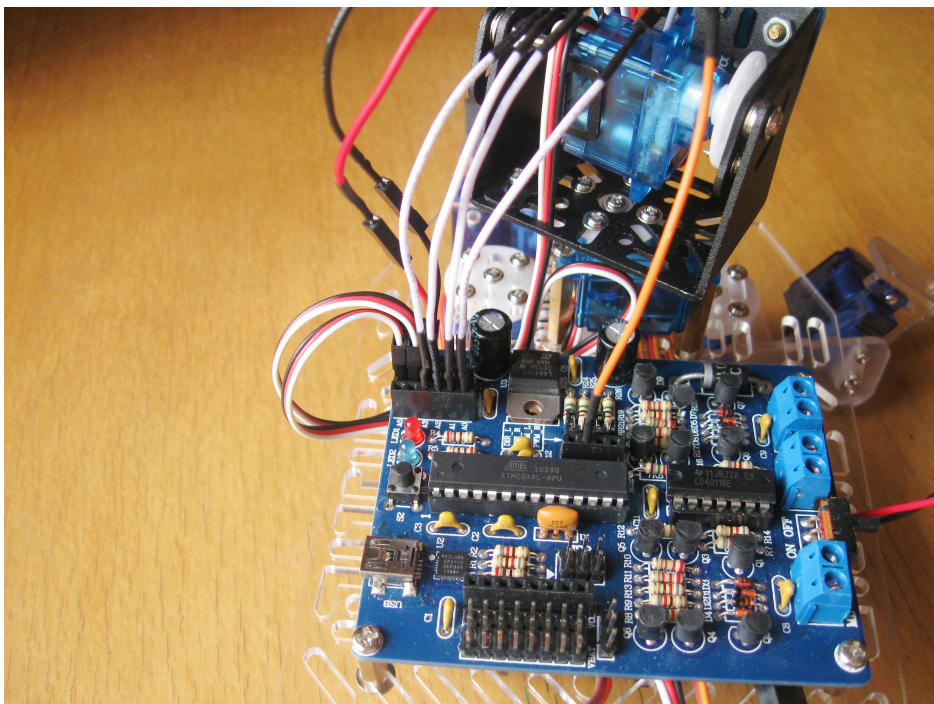

Step 19: Power configuration

The power configuration for this robot is slightly unusual. 10 miniature servos combined can draw more than 3 amps when the robot is running around. This is far more than the Magician's regulator can handle. The magician controller board does allow you to power up to 8 servos directly from the battery but the servos are rated at 6V and the battery is 7.2V!

To solve these problems, the pan and tilt servos, which are not heavily loaded, are connected to analog pins 4 and 5. These pins have been converted to servo outputs in the software and have power supplied by the 5V regulator (normally used for sensors).

This leaves the 8 leg servos to be powered directly from the battery. What we do here is to use diodes to drop the voltage to a safe level. Most silicon diodes have a forward voltage drop of about 0.6V. The Magician controller already has a 3A diode in series with the battery to protect against accidentally connecting the power around the wrong way.

This diode will drop the voltage by about 0.6V. By adding a second diode in place of the jumper that selects the servo power we effectively have two 3A diodes in series with the battery that is reducing the voltage to the servos by a total of 1.2V. Our leg servos are now getting the 6V they are rated for.

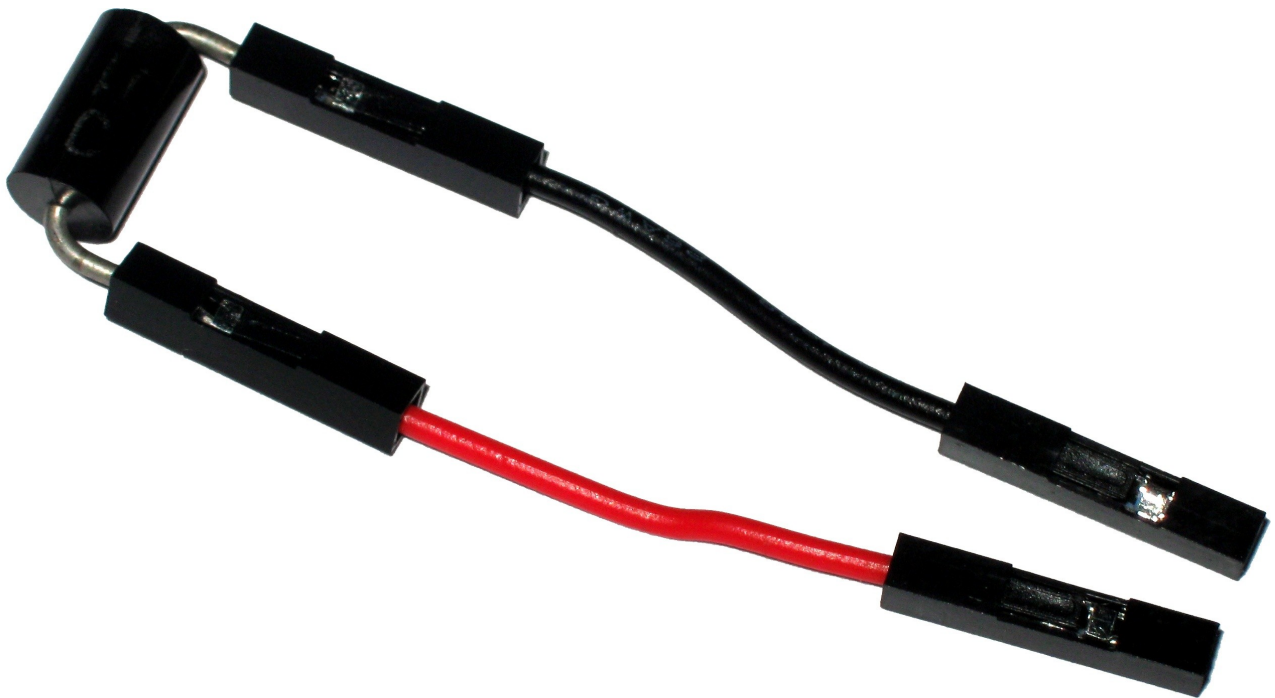

The leads on a 3A diode are slightly thicker than a male header pin. Bend the leads close to the body of the diode as shown and fit two small female-to-female jumper wires. They will be a tight fit but this is good as it ensures a good electrical connection. Fit a red wire to the anode and a black wire to the cathode.

Now remove the servo power selection jumper and fit the diode instead. Attach the red wire to VBAT and the black wire to the center pin. The servos will now receive power through this diode. If you accidentally connect the diode the wrong way around then the servos will not get power but no damage will be done.

Step 20: Connect the leg servos

Start by fitting the servo extension cables to the front leg servos. Feed these under your controller one at a time so you can tell which cable is for which servo. Plug in your leg servos as shown.

- D2 - Rear left hip
- D3 - Rear left knee
- D4 - Front left hip
- D5 - Front left knee
- D6 - Front right knee
- D11 - Front right hip
- D12 - Rear right knee
- D13 - Rear right hip

Make sure your white / orange control wire is closest to the female header.

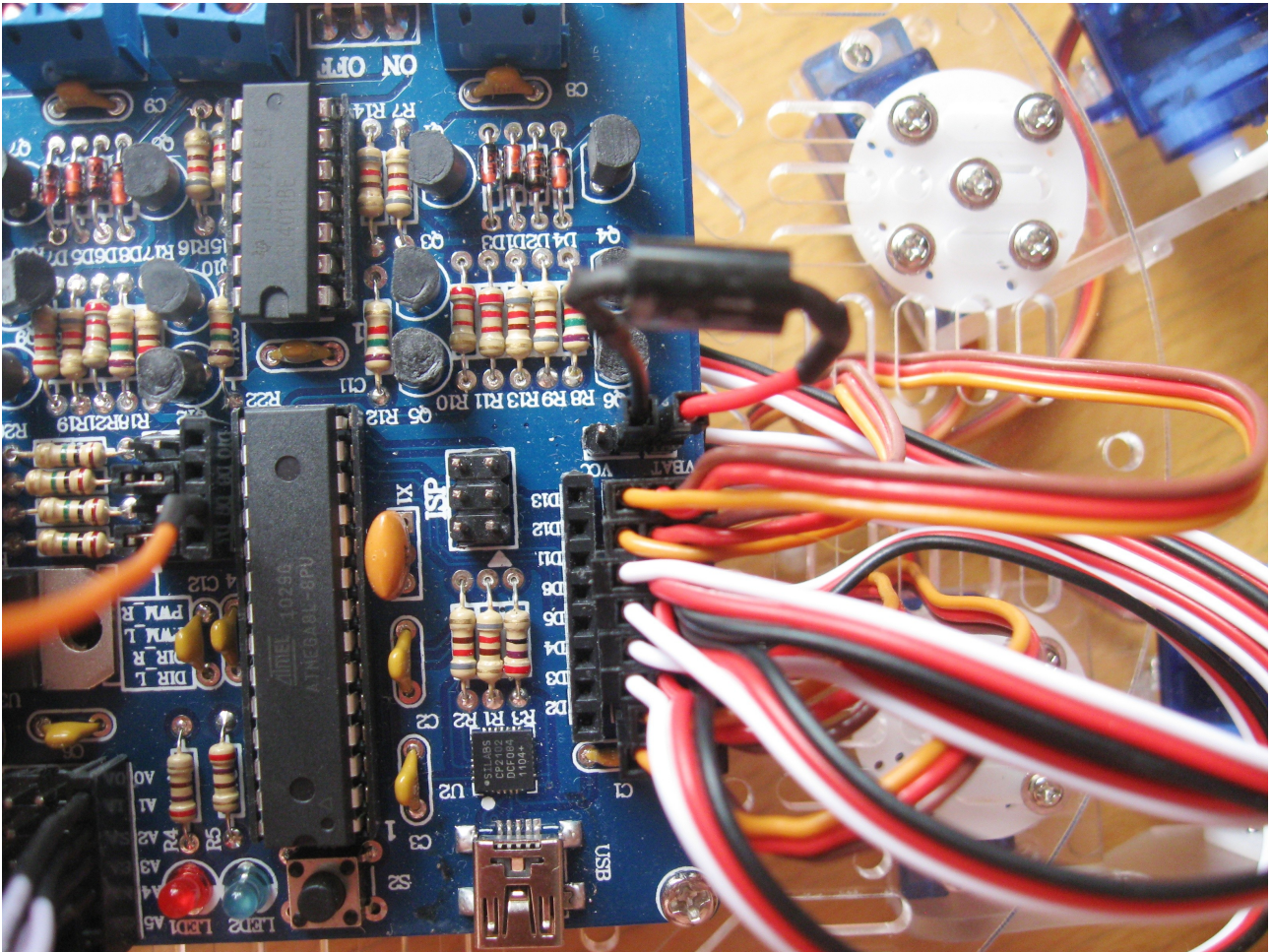

Step 21: Mount the tail

The tail is made from a piece of spiral wrap. This is normally used to tidy up wires. One end of the spiral wrap has been plugged with hot glue. Mount the tail by pushing a 2.3 x 10mm pan head self-tapping screw through the hole at the back of the mounting plate and screwing it into the plugged end of the spiral wrap.

Insert your shaker motor in the end of the tail with the wires coming out at the base. Connect the wires to the left motor output.

Make sure your power switch is off. Remove the tape from your red battery wire and screw it into the positive power terminal. Remove the tape from the black battery wire and screw it into the negative power terminal.

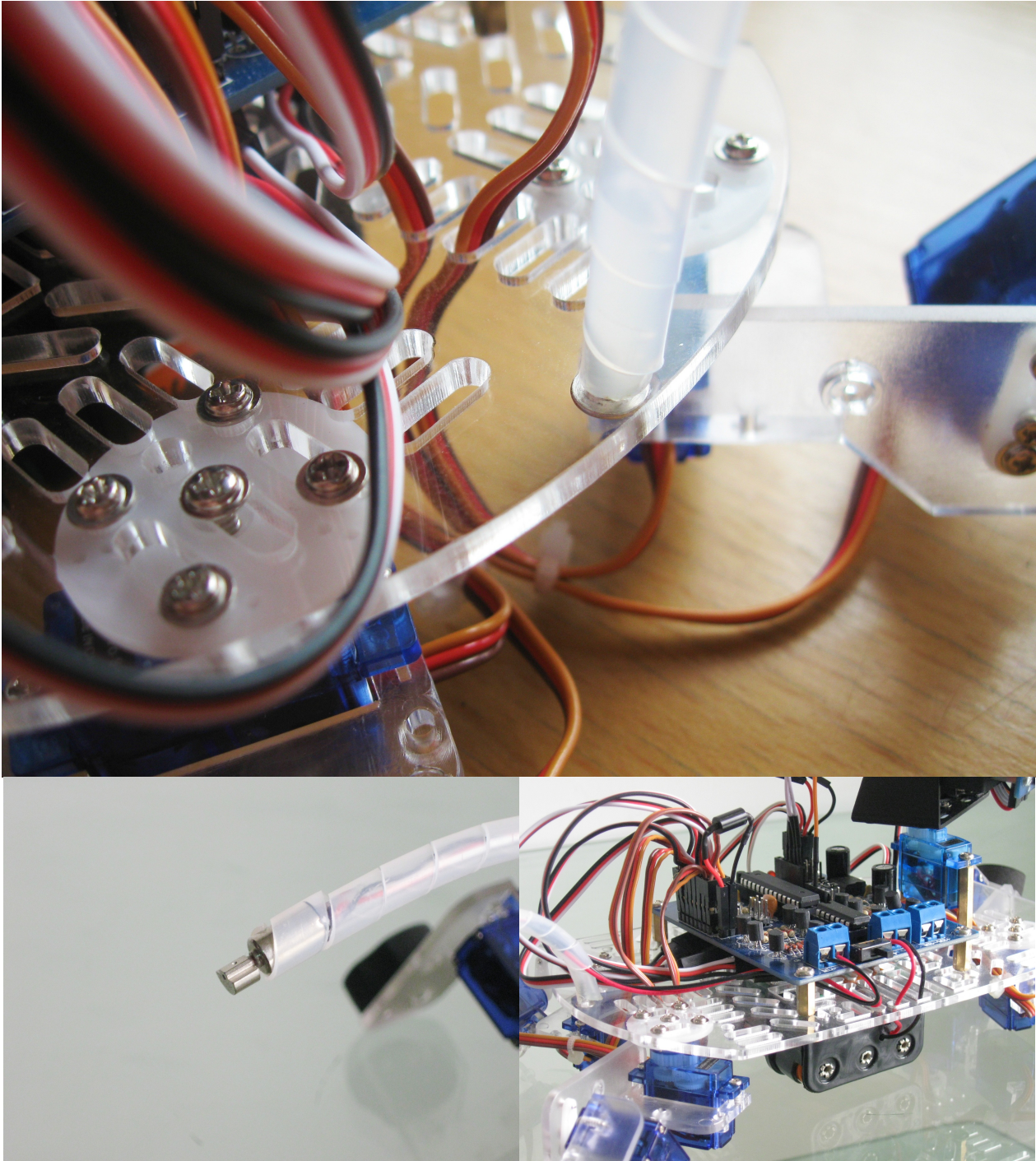

Step 22: Installing the software

To install the sample code you must first have the Arduino IDE version 18 or later running on your computer. The Arduino IDE can be downloaded for free from here: <http://arduino.cc/en/Guide/HomePage>.

The Magician controller uses the CP2102 USB interface IC. Depending on your OS you may need to install drivers. You can download the latest USB drivers. These are included on the CD or you can download the latest from here: <http://www.silabs.com/products/mcu/Pages/USBtoUARTBridgeVCPDrivers.aspx>

Once you have the Arduino IDE running, you can open the program. Make sure you have the version suited to the batteries you are using (NiMh or LiPo) so that the robot will be able to stand on its hind legs.

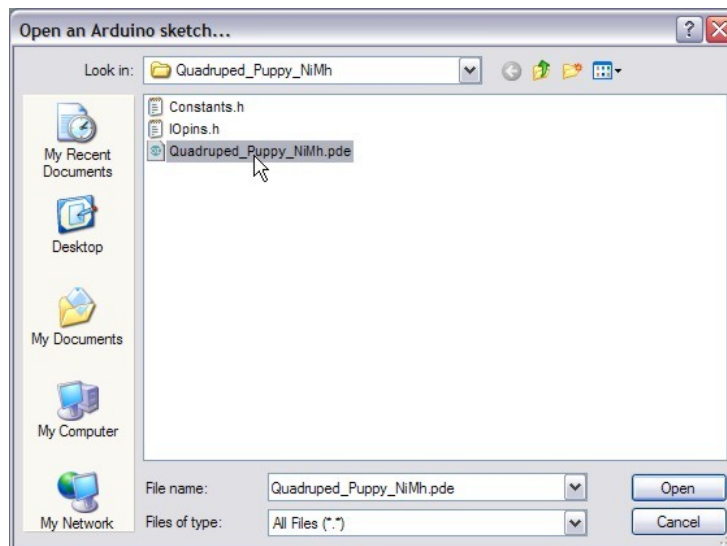

You will see that the code has a constants tab and an IO pins tab. The constants tab stores values such as the centre positions of servos. This makes it quick and easy to fine-tune your code.

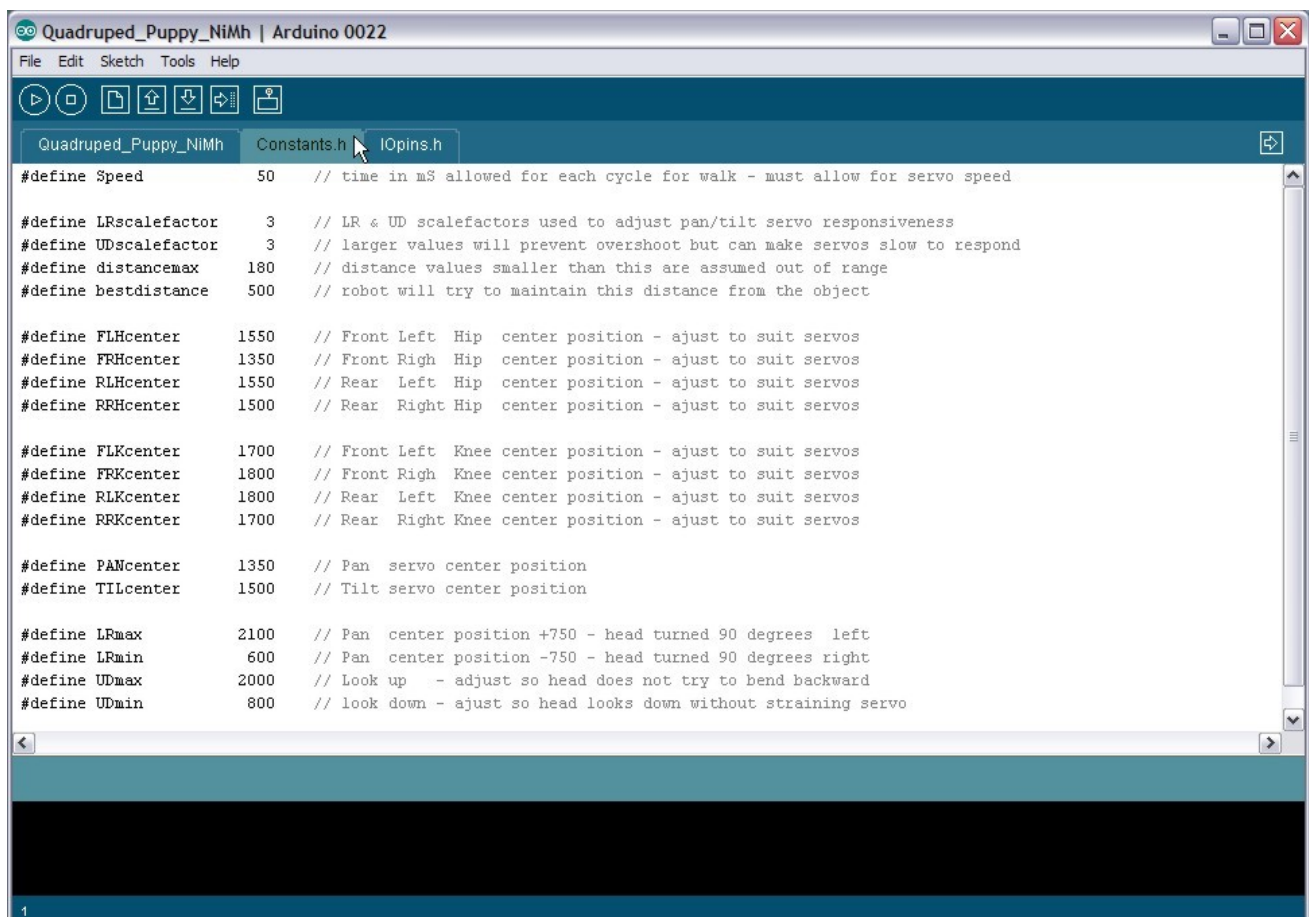

Step 22: Installing the software continued

The IOpins tab is like a map for your wiring. It tells you which device is connected to what pin.

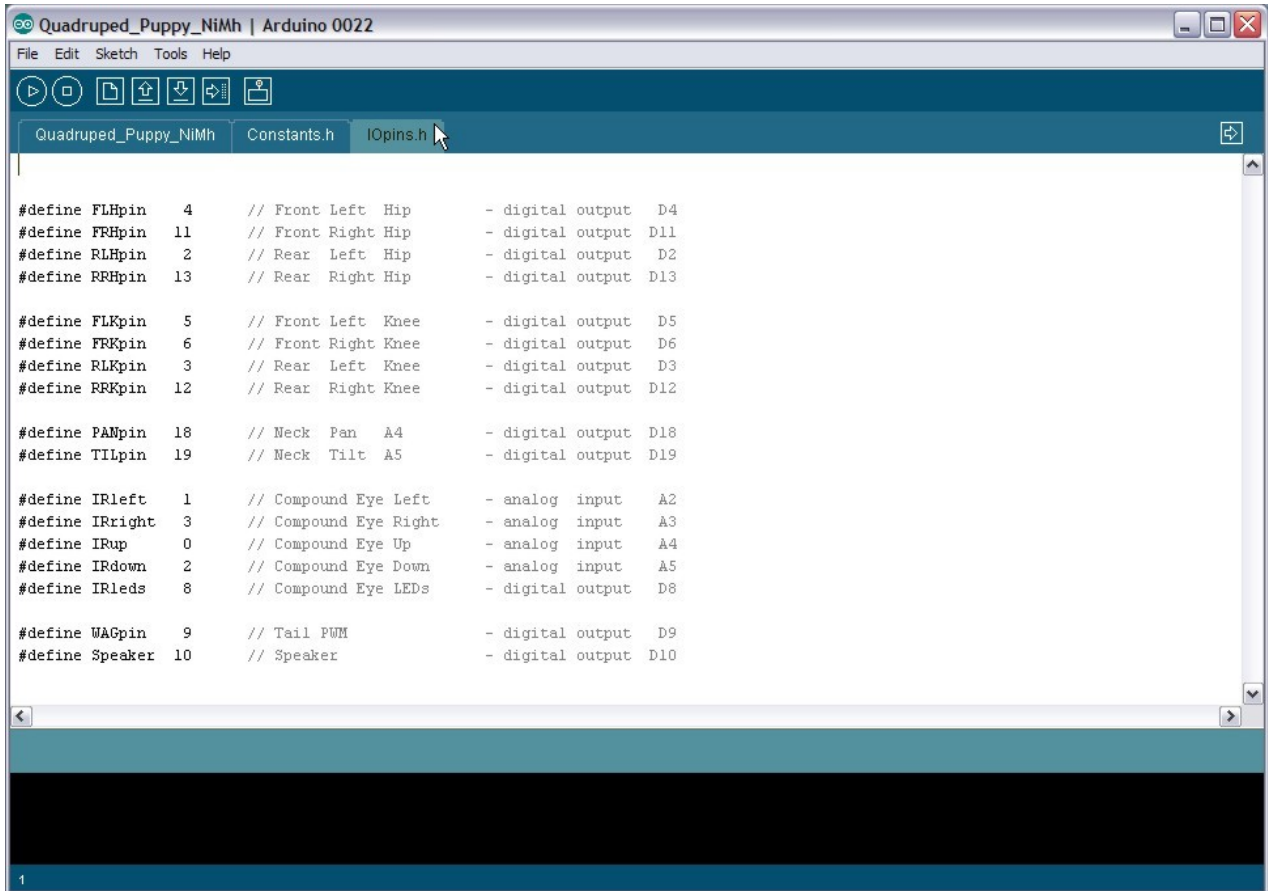

```
Quadruped_Puppy_NiMh | Arduino 0022
File Edit Sketch Tools Help
Quadruped_Puppy_NiMh Constants.h IOpins.h

#define FLHpin 4 // Front Left Hip - digital output D4
#define FRHpin 11 // Front Right Hip - digital output D11
#define RLHpin 2 // Rear Left Hip - digital output D2
#define RRHpin 13 // Rear Right Hip - digital output D13

#define FLKpin 5 // Front Left Knee - digital output D5
#define FRKpin 6 // Front Right Knee - digital output D6
#define RLKpin 3 // Rear Left Knee - digital output D3
#define RRKpin 12 // Rear Right Knee - digital output D12

#define PANpin 18 // Neck Pan A4 - digital output D18
#define TILpin 19 // Neck Tilt A5 - digital output D19

#define IRleft 1 // Compound Eye Left - analog input A2
#define IRright 3 // Compound Eye Right - analog input A3
#define IRup 0 // Compound Eye Up - analog input A4
#define IRdown 2 // Compound Eye Down - analog input A5
#define IRLeds 8 // Compound Eye LEDs - digital output D8

#define WAGpin 9 // Tail PWM - digital output D9
#define Speaker 10 // Speaker - digital output D10
```

Go to the tools menu and select your board type. The Magician controller comes with either the ATmega8A or the ATmega328. If you have the ATmega8A then select "Arduino NG or older /w ATmega8". If your controller has the ATmega328 then select "Arduino Duemilanova or Nano /w ATmega328".

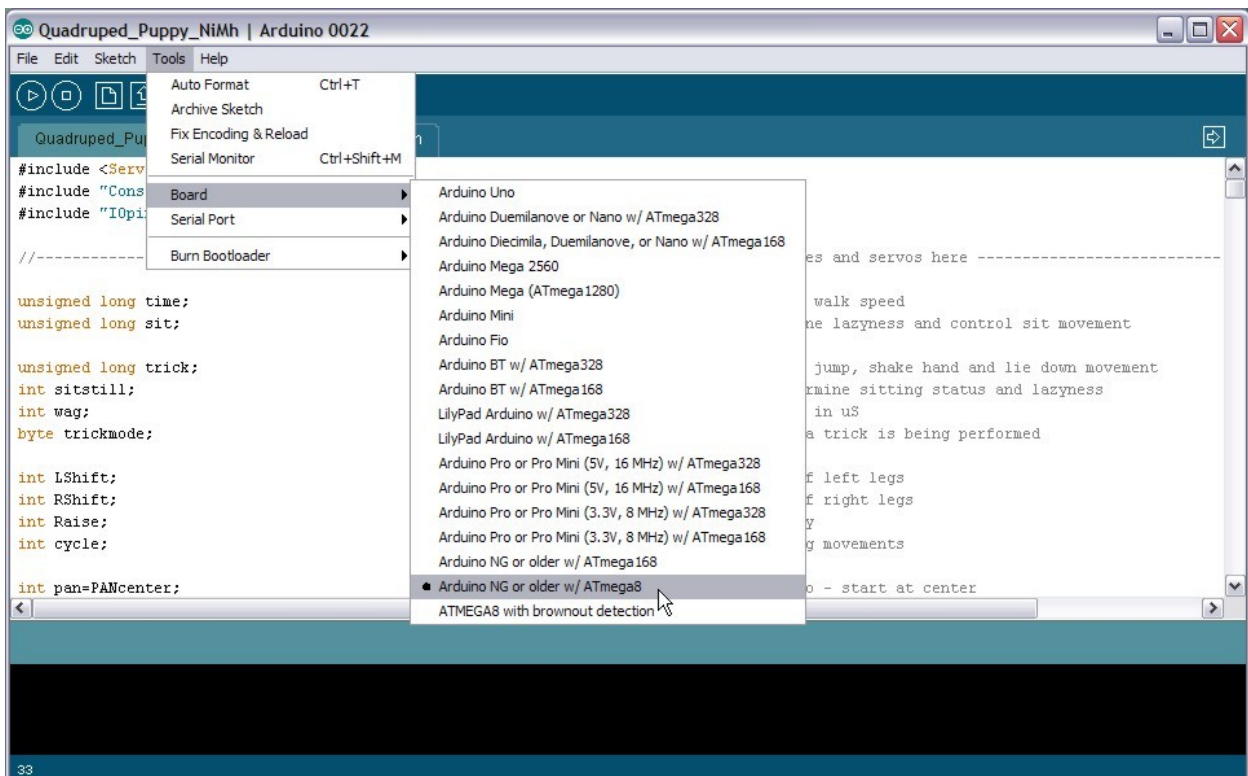

```
Quadruped_Puppy_NiMh | Arduino 0022
File Edit Sketch Tools Help
Auto Format Ctrl+T
Archive Sketch
Fix Encoding & Reload
Serial Monitor Ctrl+Shift+M
Board
Serial Port
Burn Bootloader

#include <Servo.h>
#include "Constants.h"
#include "IOpins.h"

//-----
unsigned long time;
unsigned long sit;

unsigned long trick;
int sitstill;
int wag;
byte trickmode;

int LShift;
int RShift;
int Raise;
int cycle;

int pan=PANcenter;
```

Step 22: Installing the software continued

Now switch on your robot and plug in your USB cable. After a few seconds your computer should detect the USB interface of the Magician controller. Go back to the tools menu and select your serial port.

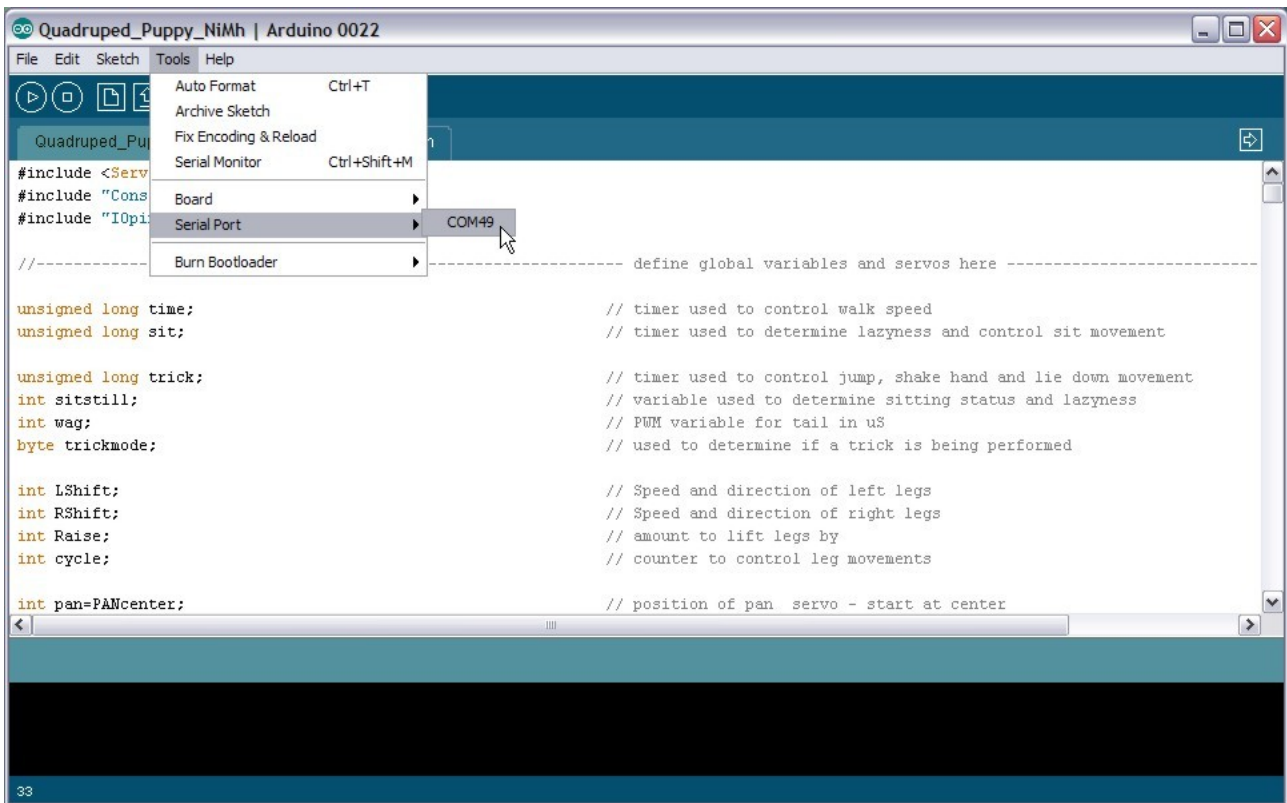

You are now ready to upload your program to the robot.

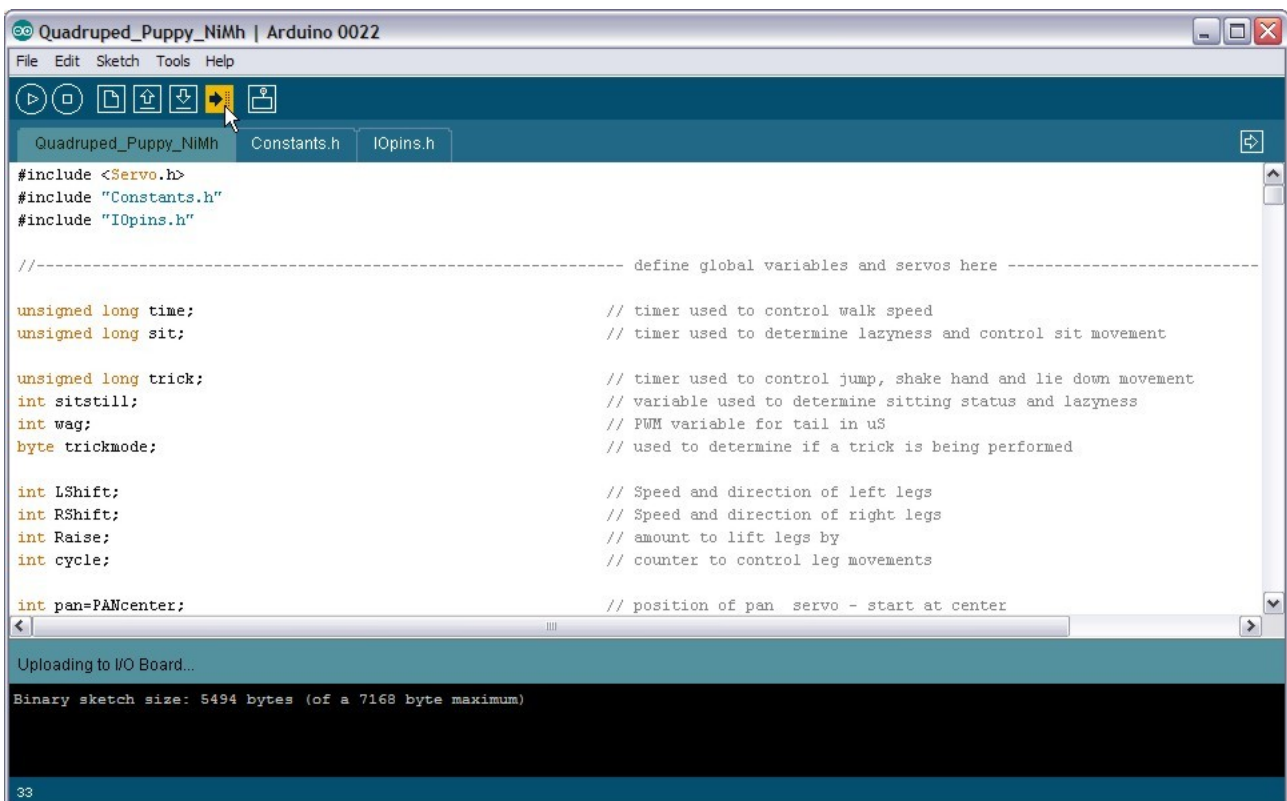

Step 23: Controlling your robot

The sample code tracks your hand movements with the compound eye and responds accordingly. If you leave the robot alone for 3 seconds then it will sit down out of boredom. Once it sits down it gets lazy and will only track your hand with its head.

If you slowly bring your hand within range and move your hand to a paw then the robot will lift that paw for you to shake hands. If you bring your hand between the paws it will lie down.

Once sitting you must excite the puppy to get it to stand back on its feet. Taking your hand to one side or above the robot so it can only just see your hand will do this. When the robot is standing it will try and maintain a set distance from your hand. It will walk forward, move backward or turn in order to keep your hand in range.

Do not move your hand too quick or it may lose sight of your hand. If you move your hand directly over its head while the robot is standing then it will try to jump on its rear legs. If your hand stays in range of the eye the robot will try and walk on its back legs to follow your hand. This trick works the best with the lighter LiPo battery.



Step 24: Trouble shooting

The robot probably won't work very well at first. Each servo is a little bit different so some tweaking is required. At the start of the main loop add the line "return;" This will cause the robot to stand still indefinitely. You can now adjust the servo center positions in the constants tab until the rear hips are at 90 degrees to the body and the front hips are slightly forward.

All knees should bend inward slightly. If any of your servos are drastically out of alignment then you may need to reset the servo horn. Your head should look straightforward with the head looking up at about a 30 - 40 degree angle.

You may need to adjust these values and re-upload the program several times to get all servos in the correct position. Once your robots servos are set correctly you can remove the "return;" line from your main loop.

If the head does not track your hand then check your eye connections. If the head turns away from your hand then you may have accidentally swapped your sensor wires or mounted the eye upside down (the wires should come out at the bottom). Double-check everything in steps 14 and 18. Are your servos plugged in correctly?

If the robot frequently resets then you may have a bad battery or battery connection. Check your batteries have a good charge and are making a good connection with the battery holder terminals. Are the battery terminal screws tight? Some cheap batteries may not be able to deliver enough current.

If the head works but the legs don't move then your diode that replaced the servo power jumper in step 19 may be around the wrong way or not plugged into the correct pins. Check step 20 to make sure you have the servos plugged in correctly with the signal wire closest to the female header.

If the robot does not walk correctly then you may have accidentally swapped hip and knee servos. The hip servo allows the leg to move forward and backward. The knee servo allows the leg to move up and down.

If the robot cannot stand on it's hind legs then check you have the correct version of the code. NiMh batteries are heavier than LiPo batteries. This affects the robots balance. You may need to play with the code or adjust the position of your batteries a bit.

If you are Using NiMh then you will probably need to remove the voltage drop diode and re-install the voltage selection jumper for the servo power. This will run your servos at 6.6V giving them more power but there is a greater chance of the servo stripping a gear or overheating.

